

Notice for TAIYO YUDEN products

Please read this notice before using the TAIYO YUDEN products.



REMINDERS

- Product information in this catalog is as of October 2008. All of the contents specified herein are subject to change without notice due to technical improvements, etc. Therefore, please check for the latest information carefully before practical application or usage of the Products.

Please note that Taiyo Yuden Co., Ltd. shall not be responsible for any defects in products or equipment incorporating such products, which are caused under the conditions other than those specified in this catalog or individual specification.

- Please contact Taiyo Yuden Co., Ltd. for further details of product specifications as the individual specification is available.
- Please conduct validation and verification of products in actual condition of mounting and operating environment before commercial shipment of the equipment.
- All electronic components or functional modules listed in this catalog are developed, designed and intended for use in general electronics equipment.(for AV, office automation, household, office supply, information service, telecommunications, (such as mobile phone or PC) etc.). Before incorporating the components or devices into any equipment in the field such as transportation,(automotive control, train control, ship control), transportation signal, disaster prevention, medical, public information network (telephone exchange, base station) etc. which may have direct influence to harm or injure a human body, please contact Taiyo Yuden Co., Ltd. for more detail in advance.

Do not incorporate the products into any equipment in fields such as aerospace, aviation, nuclear control, submarine system, military, etc. where higher safety and reliability are especially required.

In addition, even electronic components or functional modules that are used for the general electronic equipment, if the equipment or the electric circuit require high safety or reliability function or performances, a sufficient reliability evaluation check for safety shall be performed before commercial shipment and moreover, due consideration to install a protective circuit is strongly recommended at customer's design stage.

- The contents of this catalog are applicable to the products which are purchased from our sales offices or distributors (so called "TAIYO YUDEN' s official sales channel"). It is only applicable to the products purchased from any of TAIYO YUDEN' s official sales channel.
- Please note that Taiyo Yuden Co., Ltd. shall have no responsibility for any controversies or disputes that may occur in connection with a third party's intellectual property rights and other related rights arising from your usage of products in this catalog. Taiyo Yuden Co., Ltd. grants no license for such rights.
- Caution for export
Certain items in this catalog may require specific procedures for export according to "Foreign Exchange and Foreign Trade Control Law" of Japan, "U.S. Export Administration Regulations," and other applicable regulations. Should you have any question or inquiry on this matter, please contact our sales staff.
Should you have any question or inquiry on this matter, please contact our sales staff.

チップアンテナ CHIP ANTENNA

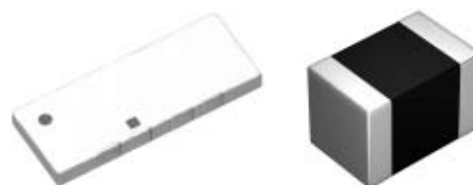

OPERATING TEMP. -20~+80°C

リフロー/REFLOW

特長 FEATURES

- ・小型・低背
- ・広帯域・高利得
- ・安定した温度特性

- ・ Compact, Lower profile.
- ・ Wide bandwidth, High Gain.
- ・ Stable temperature characteristics.

用途 APPLICATIONS

- ・ Bluetooth®, 無線LAN, GPS, WiMAX, ZigBee, UWB

- ・ Bluetooth®, Wireless LAN, GPS, WiMAX, ZigBee, UWB

形名表記法 ORDERING CODE

1	2	3	4	5	6	7
形式	電極仕様	形状寸法 [mm]	種別コード	周波数 [MHz]	個別仕様	包装
AH 積層アンテナ AF ヘリカルアンテナ	△ メッキ品 △=スペース	216 2.5 × 1.6 816 8.0 × 1.6 116 11.0 × 1.6 316 3.2 × 1.6 083 8.0 × 3.0 104 10.0 × 4.0 122 12.0 × 2.0 042 4.0 × 2.0 086 8.0 × 6.0	F 逆F M モノポール N モノポール(デュアルバンド)	例 1575 1574.397~1576.443 2450 2400~2500 5250 5150~5350 5550 3100~8000	01~ S1~ AH 104Fに適用	-T テーピング
				1. 中心周波数を記載。 2. デュアルバンドは下の周波数。		

A F △ 2 1 6 M 2 4 5 0 0 1 - T

1 2 3 4 5 6 7

1	2	3	4	5	6	7
Type	Electrode Code	Dimensions (case size) [mm]	Special Code	Frequency [MHz]	Spec Code	Packaging
AH Multilayer Antenna AF Helical Antenna	△ With Plating △=Blank space	216 2.5 × 1.6 816 8.0 × 1.6 116 11.0 × 1.6 316 3.2 × 1.6 083 8.0 × 3.0 104 10.0 × 4.0 122 12.0 × 2.0 042 4.0 × 2.0 086 8.0 × 6.0	F Inverted F M Mono Pole N Mono Pole (Dual)	example 1575 1574.397~1576.443 2450 2400~2500 5250 5150~5350 5550 3100~8000	01~ S1~ Applicable to AH 104F	-T Tape & Reel
				1. Describe Center Frequency 2. Lower Frequency for Dualband		

外形寸法 EXTERNAL DIMENSIONS

■ AF 216M Type, AF 816M Type, AF 116M Type

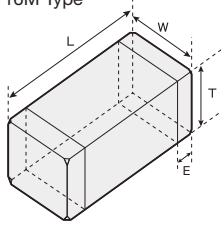

■ AH 316M Type

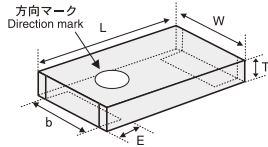

■ AH 083F Type

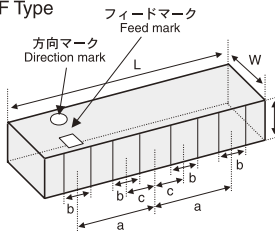

■ AH 104F Type

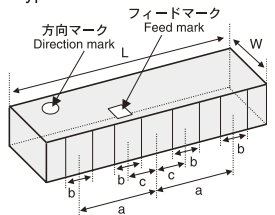

■ AH 122F Type

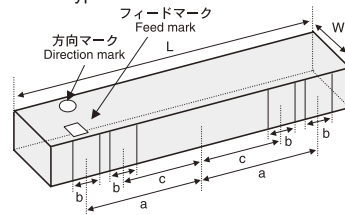

■ AH 042F Type

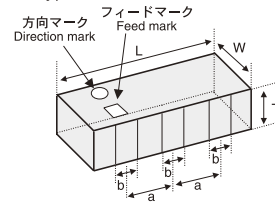

■ AH 104N Type

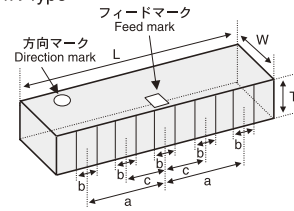

■ AH 086M Type

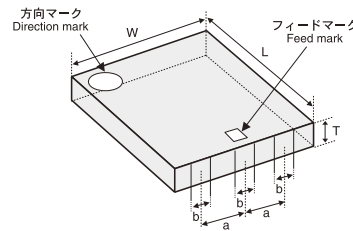

Unit : mm

Type	L	W	T	E	a	b	c
AF 216M	2.5±0.2	1.6±0.2	1.6±0.2	0.5±0.3	-	-	-
AF 816M	8±0.2	1.6±0.2	1.6±0.2	0.5±0.3	-	-	-
AF 116M	11±0.2	1.6±0.2	1.6±0.2	0.5±0.3	-	-	-
AH 316M	3.2±0.15	1.6±0.15	0.5±0.1	0.5±0.2	-	Min 1.0	-
AH 083F	8±0.3	3±0.3	1±0.3	-	3.1±0.3	1±0.3	1.15±0.3

Type	L	W	T	E	a	b	c
AH 104F	10±0.3	4±0.3	1±0.3	-	2.5±0.3	1±0.3	1±0.3
AH 122F	12±0.3	2±0.3	0.95±0.3	-	5.1±0.3	1±0.3	3.1±0.3
AH 042F	4±0.3	2±0.2	0.8±0.2	-	1.3±0.3	0.6±0.3	-
AH 104N	10±0.3	4±0.3	1±0.3	-	3±0.3	0.8±0.3	1.5±0.3
AH 086M	8±0.3	6±0.3	1±0.3	-	1.8±0.2	1±0.3	-

アイテム一覧 PART NUMBERS

用途 Applications	形名 Ordering Code	外形寸法 (mm) External Dimensions	中心周波数 (MHz) Center Frequency
GPS	AF 816M157502	8.0 × 1.6 × 1.6	1575
	AF 116M157502	11.0 × 1.6 × 1.6	1575
W-LAN (2.4GHz) Bluetooth® WiMAX (2.5GHz) ZigBee	AF 216M245001	2.5 × 1.6 × 1.6	2450
	AH 316M245001	3.2 × 1.6 × 0.5	2450
	AH 083F245001	8.0 × 3.0 × 1.0	2450
	AH 104F2450S1	10.0 × 4.0 × 1.0	2450
	AH 104F2650S1	10.0 × 4.0 × 1.0	2650
	AH 122F245001	12.0 × 2.0 × 0.95	2450
W-LAN(5GHz)	AH 042F525001	4.0 × 2.0 × 0.8	5250
W-LAN(2.4GHz / 5GHz)	AH 104N2450D1	10.0 × 4.0 × 1.0	2450 / 5400
UWB & WiMAX (3.5GHz)	AH 086M555003	8.0 × 6.0 × 1.0	5550

セレクションガイド
Selection Guide

アイテム一覧
Part Numbers

特性図
Electrical Characteristics

梱包
Packaging

信頼性
Reliability Data

使用上の注意
Precautions



etc

△当社カタログをご使用の際には「当社製品に関するお断り」を必ずお読みください。

TAIYO YUDEN 2009

△Please read the "Notice for TAIYO YUDEN products" before using this catalog.

弊社標準基板上での代表的な特性例 Typical Characteristics on Taiyo Yuden evaluation board

■ AF 216M245001

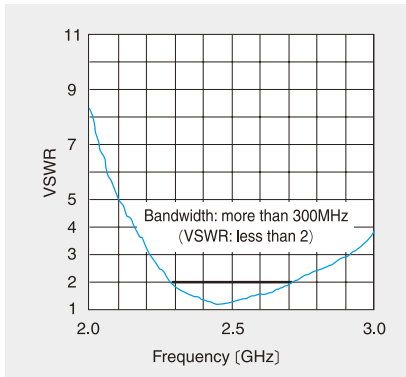

VSWR特性の代表例
Typical characteristics of VSWR

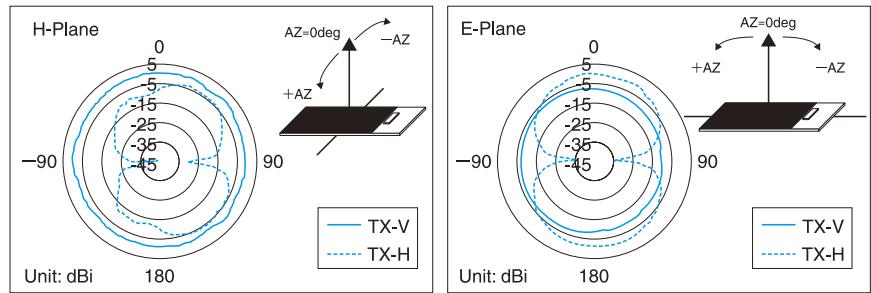

指向性の代表例 (@2.45GHz)
Typical characteristics of radiation pattern (@2.45GHz)

■ AF 816M157502

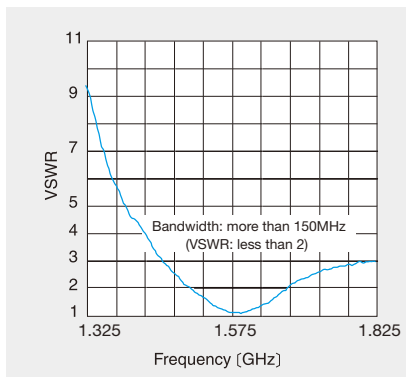

VSWR特性の代表例
Typical characteristics of VSWR

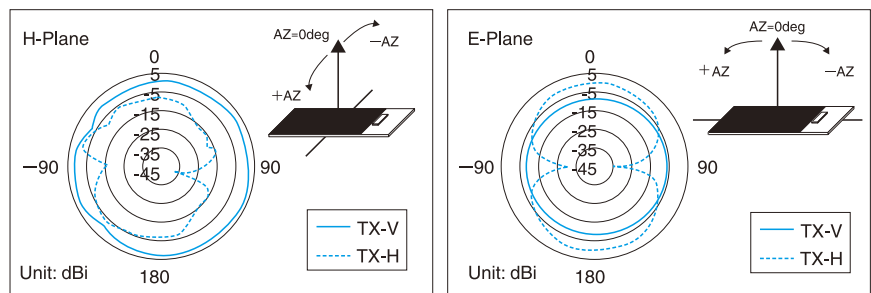

指向性の代表例 (@1.575GHz)
Typical characteristics of radiation pattern (@1.575GHz)

■ AH 116M157502

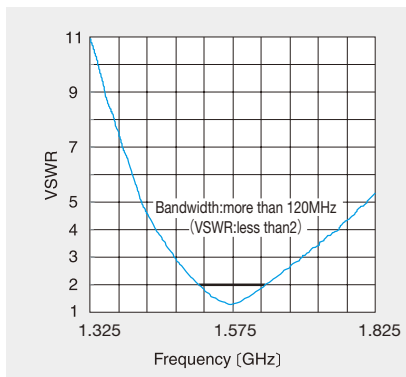

VSWR特性の代表例
Typical characteristics of VSWR

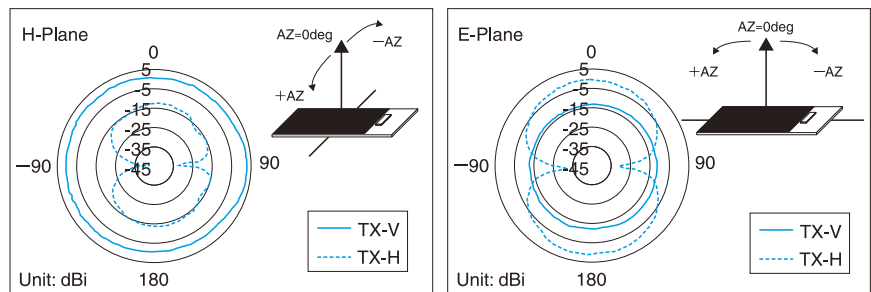

指向性の代表例 (@1.575GHz)
Typical characteristics of radiation pattern (@1.575GHz)

■ AH 316M245001

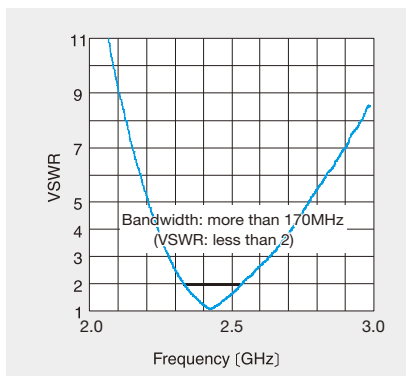

VSWR特性の代表例
Typical characteristics of VSWR

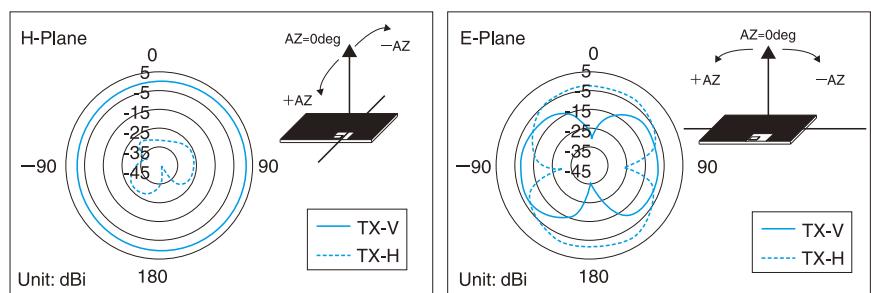

指向性の代表例 (@2.45GHz)
Typical characteristics of radiation pattern (@2.45GHz)

■ AH 083F245001

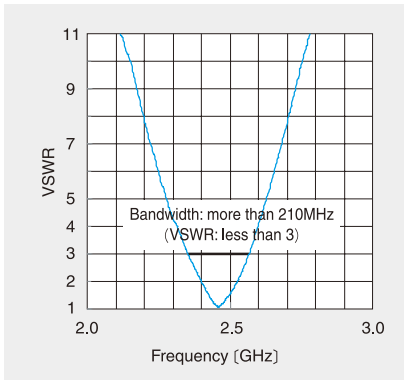

VSWR特性の代表例
Typical characteristics of VSWR

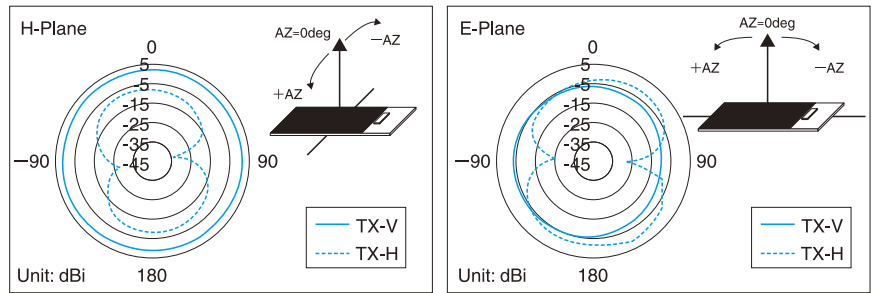

指向性の代表例 (@2.45GHz)
Typical characteristics of radiation pattern (@2.45GHz)

■ AH 104F2450S1

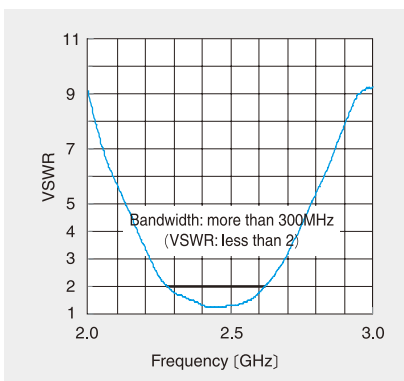

VSWR特性の代表例
Typical characteristics of VSWR

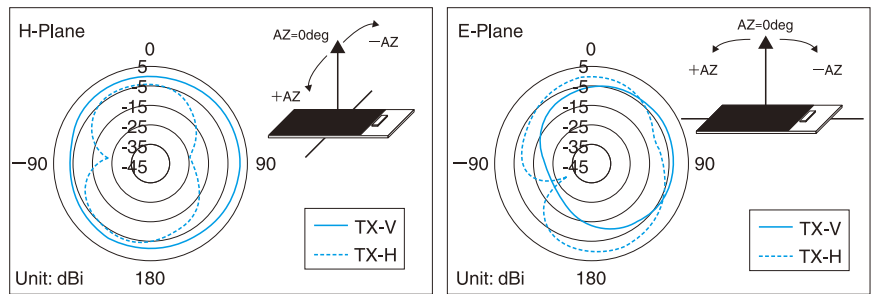

指向性の代表例 (@2.45GHz)
Typical characteristics of radiation pattern (@2.45GHz)

■ AH 122F245001

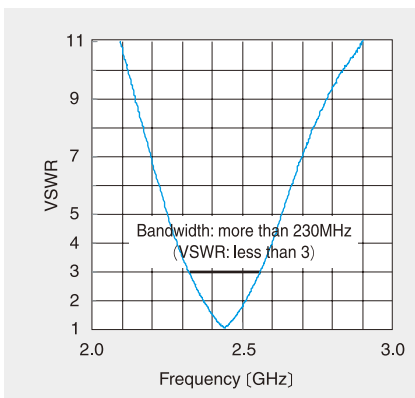

VSWR特性の代表例
Typical characteristics of VSWR

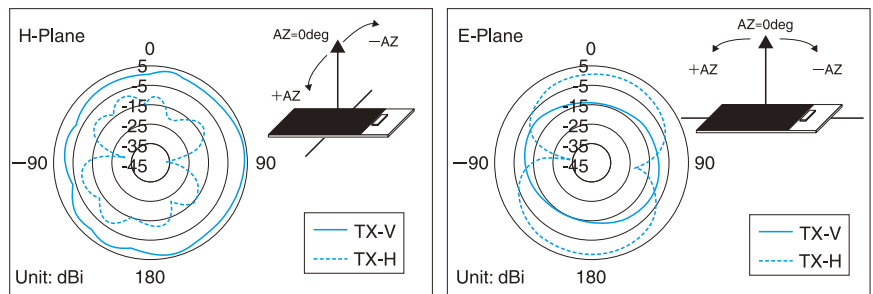

指向性の代表例 (@2.45GHz)
Typical characteristics of radiation pattern (@2.45GHz)

■ AH 042F525001

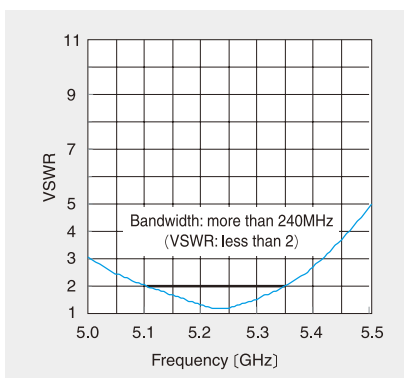

VSWR特性の代表例
Typical characteristics of VSWR

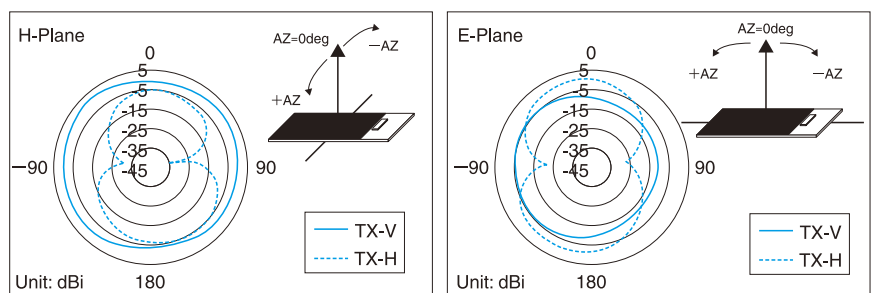

指向性の代表例 (@5.25GHz)
Typical characteristics of radiation pattern (@5.25GHz)

■ AH 104N2450D1

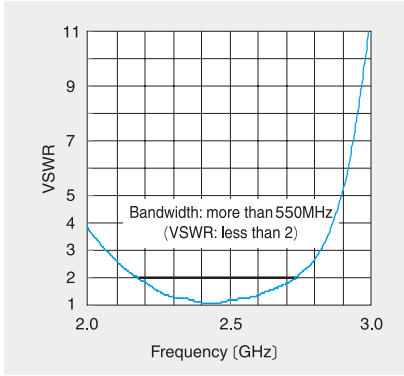

VSWR特性の代表例 (2GHz帯)
Typical characteristics of VSWR (2GHz band)

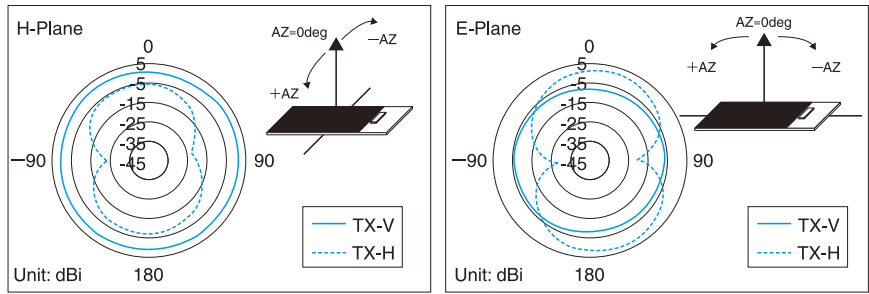

指向性の代表例 (@2.45GHz)
Typical characteristics of radiation pattern (@2.45GHz)

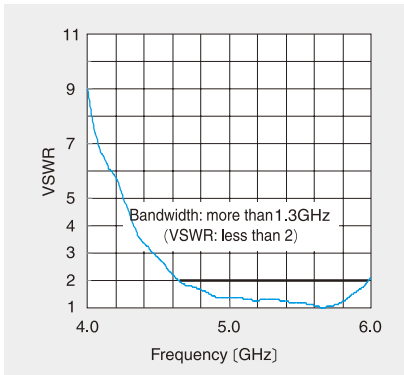

VSWR特性の代表例 (5GHz帯)
Typical characteristics of VSWR (5GHz band)

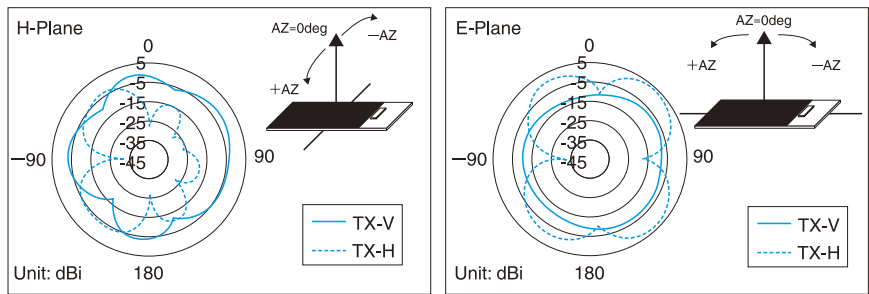

指向性の代表例 (@5.4GHz)
Typical characteristics of radiation pattern (@5.4GHz)

■ AH 086M555003

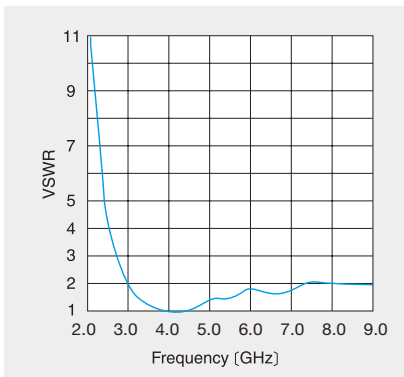

VSWR特性の代表例
Typical characteristics of VSWR

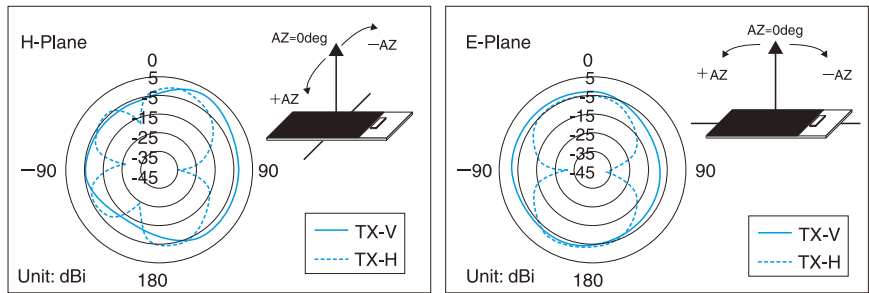

指向性の代表例 (@3.96GHz)
Typical characteristics of radiation pattern (@3.96GHz)

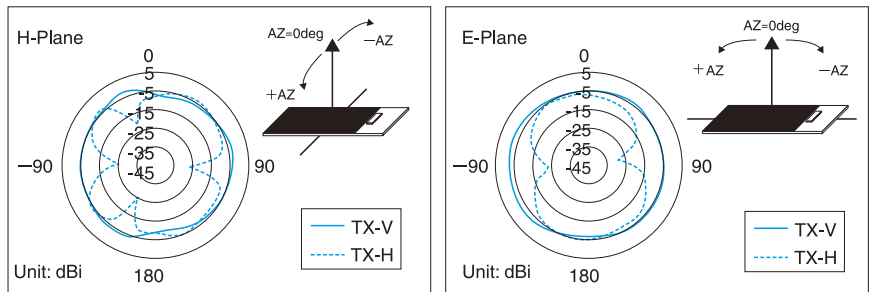

指向性の代表例 (@7.128GHz)
Typical characteristics of radiation pattern (@7.128GHz)

①最小受注単位数 Minimum Quantity

形式 Type	標準数量 (pcs) Standard Quantity エンボステープ Embossed Tape
AF 216M, AF 816M, AF 116M, AH 104F, AH 122F, AH 104N, AH 042F	2000
AH 316M	3000
AH 083F, AH 086M	1000

②テーピング材質 Tape Material

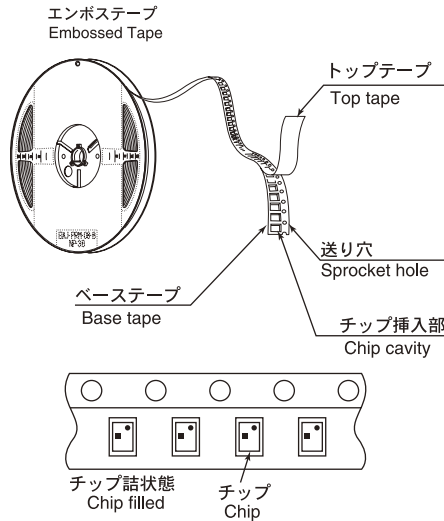

③テーピング寸法 Taping Dimensions
エンボステープ Embossed Tape

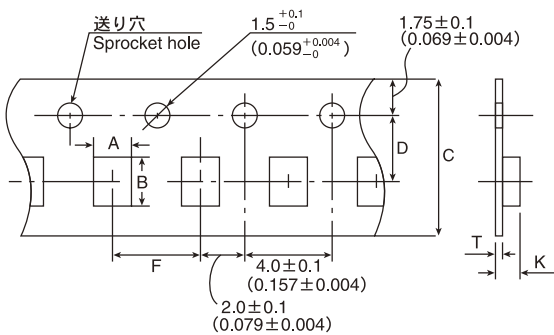

④リーダー部・空部 Leader and Blank Portion

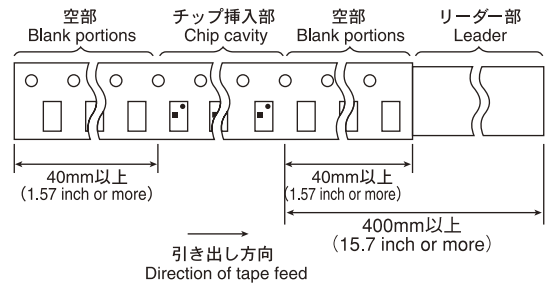

⑤リール寸法 Reel Size

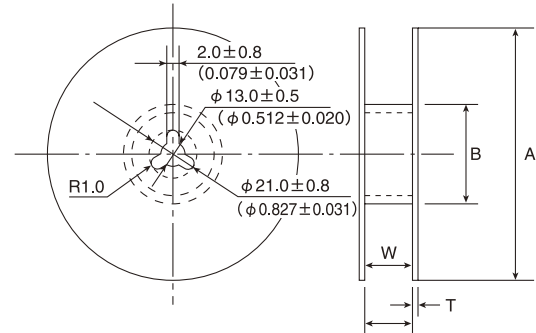

Type	A	B	W	T
AF 216M	178 ± 2.0	50MIN	10.0 ± 1.5	3.0MAX
AH 316M	(7.0 ± 0.08)	(2.0MIN)	(0.394 ± 0.06)	(0.12MAX)
AF 816M	178 ± 2.0	50MIN	17.0 ± 1.0	2.5MAX
AH 083F	(7.0 ± 0.08)	(2.0MIN)	(0.67 ± 0.04)	(0.1MAX)
AF 116M, AH 104F	330 ± 2.0	100 ± 1.0	25.5 ± 1.0	3.0MAX
AH 122F, AH 104N	(13.0 ± 0.08)	(3.94 ± 0.04)	(1.0 ± 0.04)	(0.12MAX)
AH 042F	178 ± 2.0	50MIN	14.0 ± 1.0	2.5MAX
	(7.0 ± 0.08)	(2.0MIN)	(0.55 ± 0.04)	(0.1MAX)
AH 086M	330 ± 2.0	100 ± 1.0	17.0 ± 1.0	2.5 MAX
	(13.0 ± 0.08)	(3.94 ± 0.04)	(0.67 ± 0.04)	(0.1 MAX)

Unit : mm (inch)

⑥トップテープ強度 Top Tape Strength

トップテープのはがし力は下図矢印方向にて0.1~0.7Nとなります。

The top tape requires a peel-off force of 0.1~0.7N in the direction of the arrow as illustrated below.

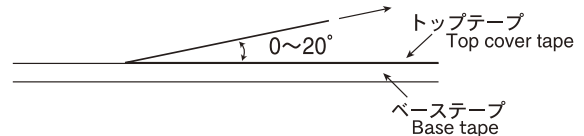

形式 Type	チップ挿入部 Chip Cavity		テープ幅 Tape Width		挿入ピッチ Insertion Pitch	テープ厚みMAX Tape Thickness	
	A	B	C	D		K	T
AF 216M	1.85 ± 0.2 (0.073 ± 0.008)	2.75 ± 0.2 (0.108 ± 0.008)	8 ± 0.2 (0.315 ± 0.008)	3.5 ± 0.1 (0.138 ± 0.004)	4 ± 0.1 (0.157 ± 0.004)	2.25 (0.089)	0.3 (0.012)
AF 816M	1.95 ± 0.2 (0.077 ± 0.008)	8.4 ± 0.2 (0.331 ± 0.008)	16 ± 0.3 (0.630 ± 0.012)	7.5 ± 0.1 (0.296 ± 0.004)	4 ± 0.1 (0.157 ± 0.004)	2.4 (0.095)	0.35 (0.014)
AF 116M	1.95 ± 0.2 (0.077 ± 0.008)	11.4 ± 0.2 (0.449 ± 0.008)	24 ± 0.3 (0.945 ± 0.012)	11.5 ± 0.1 (0.453 ± 0.004)	4 ± 0.1 (0.157 ± 0.004)	2.4 (0.095)	0.35 (0.014)
AH 316M	1.9 ± 0.2 (0.075 ± 0.008)	3.5 ± 0.2 (0.138 ± 0.008)	8 ± 0.2 (0.315 ± 0.012)	3.5 ± 0.1 (0.138 ± 0.004)	4 ± 0.1 (0.157 ± 0.004)	1.15 (0.045)	0.3 (0.012)
AH 083F	3.35 ± 0.2 (0.132 ± 0.008)	8.35 ± 0.2 (0.329 ± 0.008)	16 ± 0.3 (0.630 ± 0.012)	7.5 ± 0.1 (0.295 ± 0.004)	8 ± 0.1 (0.315 ± 0.004)	1.75 (0.069)	0.3 (0.012)
AH 104F, AH 104N	4.35 ± 0.2 (0.171 ± 0.008)	10.35 ± 0.2 (0.407 ± 0.008)	24 ± 0.3 (0.945 ± 0.012)	11.5 ± 0.1 (0.435 ± 0.004)	8 ± 0.1 (0.315 ± 0.004)	1.75 (0.069)	0.3 (0.012)
AH 122F	2.3 ± 0.2 (0.091 ± 0.008)	12.3 ± 0.2 (0.484 ± 0.008)	24 ± 0.3 (0.945 ± 0.012)	11.5 ± 0.1 (0.435 ± 0.004)	4 ± 0.1 (0.157 ± 0.004)	1.7 (0.067)	0.35 (0.014)
AH 042F	2.3 ± 0.2 (0.091 ± 0.008)	4.3 ± 0.2 (0.169 ± 0.008)	12 ± 0.2 (0.473 ± 0.008)	5.5 ± 0.1 (0.217 ± 0.004)	4 ± 0.1 (0.157 ± 0.004)	1.45 (0.057)	0.3 (0.012)
AH 086M	6.25 ± 0.2 (0.246 ± 0.008)	8.26 ± 0.2 (0.325 ± 0.008)	16 ± 0.3 (0.630 ± 0.012)	7.5 ± 0.1 (0.296 ± 0.004)	12 ± 0.1 (0.473 ± 0.004)	1.6 (0.063)	0.3 (0.012)

Unit : mm (inch)

Item	Specified Value	Test Methods and Remarks
1. Operating Temperature Range	-20~+80°C	
2. Storage Temperature Range	-40~+85°C	※with being taped, -20~+35°C
3. Solderability	At least 90% of Terminal surface immersed is covered by new solder.	Solder temperature : 230±5°C Duration : 3±1 sec. Preconditioning : Preheating at 150°C after immersion into flux.
4. Thermal Shock	Shall satisfy required VSWR value of individual specifications for each item.	1 hour of recovery after 10 times of 30min.immersion alternately at -40°C and 85°C of temperature, followed by evaluating electrical characteristics.
5. High Temperature Storage Test	Shall satisfy required VSWR value of individual specifications for each item.	1 hour of recovery under standard condition after 96 hours recovery with 85°C of temperature, followed by evaluating electrical characteristics.
6. Low Temperature Storage Test	Shall satisfy required VSWR value of individual specifications for each item.	1 hour of recovery under standard condition after 96 hours recovery with -40°C of temperature, followed by evaluating electrical characteristics.
7. Humidity Storage Test	Shall satisfy required VSWR value of individual specifications for each item.	1 hour of recovery under standard condition after 96 hours recovery with 60°C of temperature, 90~95% relative humidity followed by evaluating electrical characteristics.
8. Resistance to Reflow	Shall satisfy required VSWR value of individual specifications for each item.	Two times of reflow soldering by recommended profile attached, followed by evaluating electrical characteristics.

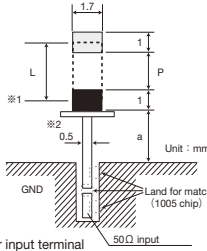
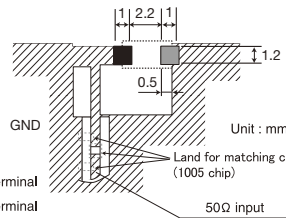
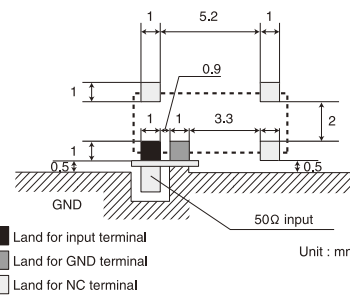
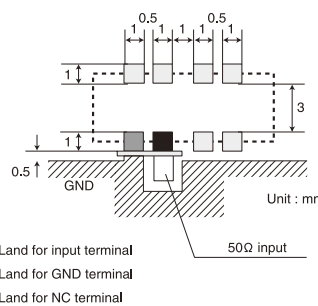
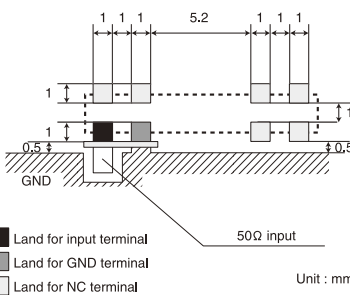
Stages	Precautions	Technical Considerations																			
<p>1. PCB Design</p>	<p>Land pattern design</p> <p>Please don't arrange the surface and inside layer pattern near the antenna mounting area.</p>	<p>Land pattern dimension examples</p> <ul style="list-style-type: none"> Recommended antenna land pattern for AF 216M/816M/116M <table border="1" data-bbox="1228 323 1468 447"> <thead> <tr> <th rowspan="2">Type</th> <th colspan="3">Dimensions</th> </tr> <tr> <th>L</th> <th>P</th> <th>a</th> </tr> </thead> <tbody> <tr> <td>AF 216M</td> <td>2.5</td> <td>1.5</td> <td>3</td> </tr> <tr> <td>AF 816M</td> <td>8</td> <td>7</td> <td>5</td> </tr> <tr> <td>AF 116M</td> <td>11</td> <td>10</td> <td>3</td> </tr> </tbody> </table> <p>Unit: mm</p>  Recommended antenna land pattern for AH 316M  Recommended antenna land pattern for AH 083F  Recommended antenna land pattern for AH 104F  Recommended antenna land pattern for AH 122F  	Type	Dimensions			L	P	a	AF 216M	2.5	1.5	3	AF 816M	8	7	5	AF 116M	11	10	3
Type	Dimensions																				
	L	P	a																		
AF 216M	2.5	1.5	3																		
AF 816M	8	7	5																		
AF 116M	11	10	3																		

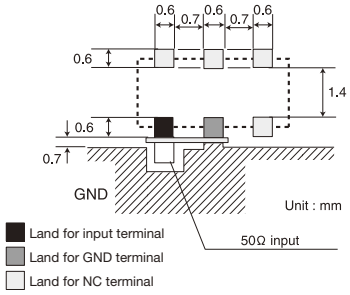
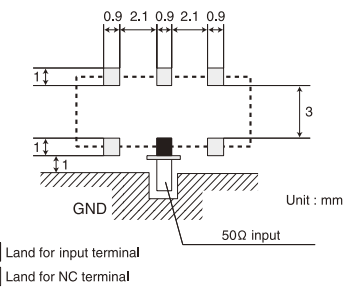
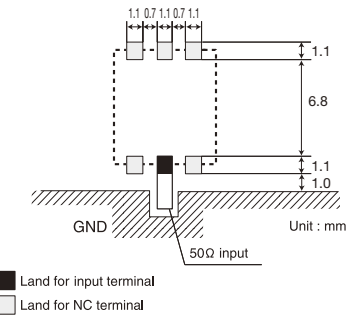
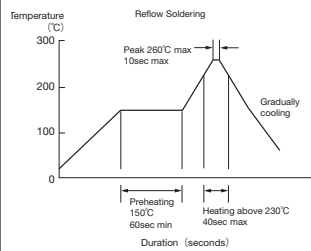
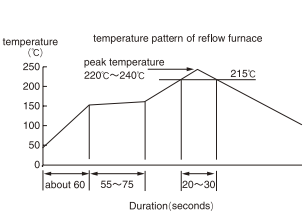
Stages	Precautions	Technical Considerations
1. PCB Design		<p>• Recommended antenna land pattern for AH 042F</p>  <p>• Recommended antenna land pattern for AH 104N</p>  <p>• Recommended antenna land pattern for AH 086M</p> 
2. Soldering		<p>Conditions of Reflow soldering (for reference)</p> <p>Pb Free Reflow Profile</p>  <p>Reflow Profile</p>  <p>※Components should be preheated to within 100 to 130°C from soldering temperature. ※Assured to be reflow soldering for 2 times.</p> <p>Note : The above profiles are the maximum allowable soldering condition, therefore these profiles are not always recommended.</p>
3. Storage Conditions	<p>◆ Storage conditions</p> <ol style="list-style-type: none"> The Products should not be used in the following environments : <ul style="list-style-type: none"> • exposure to special gases such as (C12, NH3, SOx, NOx) • exposure to volatile gas or inflammable gas • exposure to a lot of dust • exposure to water or condensation • exposure to direct sunlight or freezing The Products should be kept in the following conditions : <ul style="list-style-type: none"> • Temperature : - 10 ~ + 40°C • Humidity : 15 ~ 85% RH The products should be used within 6 months after delivery. In case of storage over 6 months, solderability shall be checked before actual usage. 	

■ Please contact our offices for further details of specifications.

All of the standard values listed here are subject to change without notice due to technical improvements.

Therefore, please check the specifications carefully before use.